

### Ash Drawer Housing

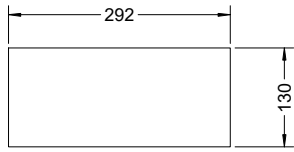

End Cap

### Ash Drawer Front

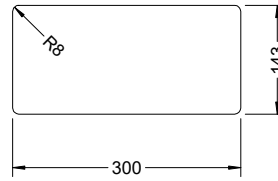

### Ash Drawer Back

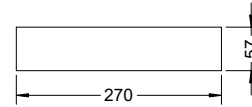

### Back View

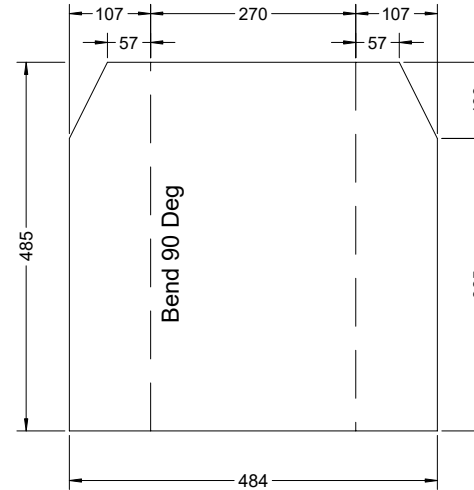
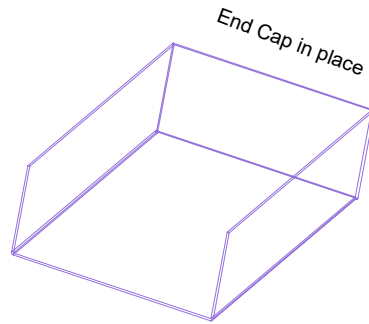
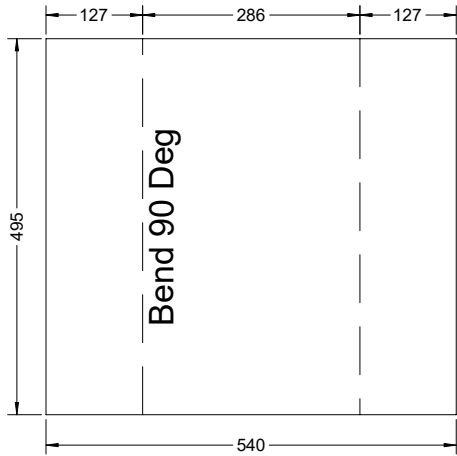
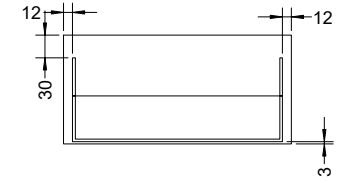

Bend the body and centre the front on the body. Weld on the inside.

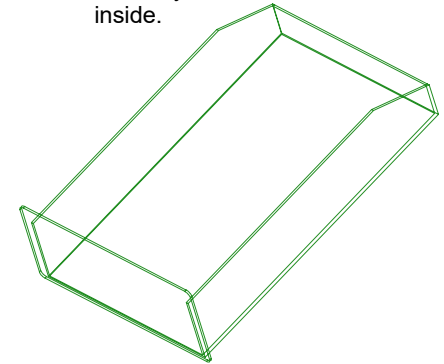

540 x 495 x 2 or 3 mm steel sheet

500 x 485

Add any suitable handle

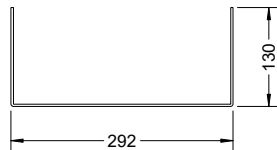

**\*\*Important\*\***

The Ash Drawer Housing is mounted so the open end is with the end of the stove body not recessed. The drawer front must completely close air gaps so no air can enter around the ash drawer.

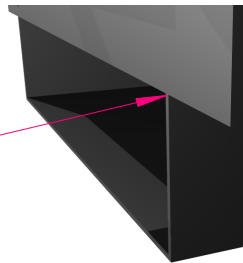

### ASH DRAWER

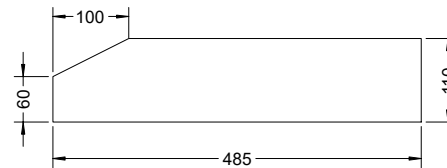

Dwg. TJ4.1.42.04

Model 4 A and B  
Version 1.42  
23 Feb 2017

C Pemberton-Pigott